

BEKT-S1501CII

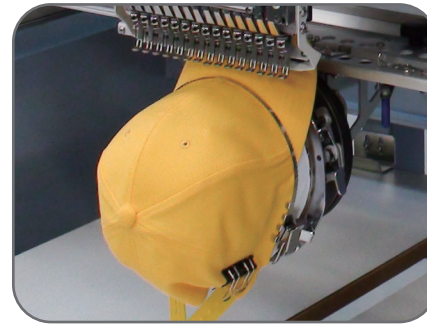

Barudan
THE MOST ADVANCED EMBROIDERY MACHINE SINCE 1959

Accessories



Wide Cap Frame



Pocket Frames

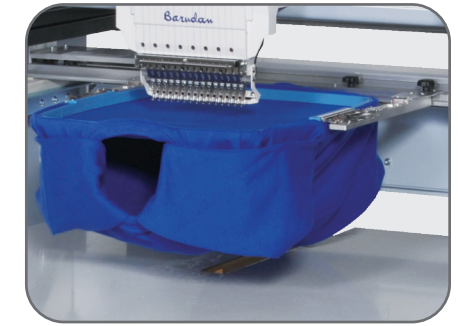

Frames for Finished Products

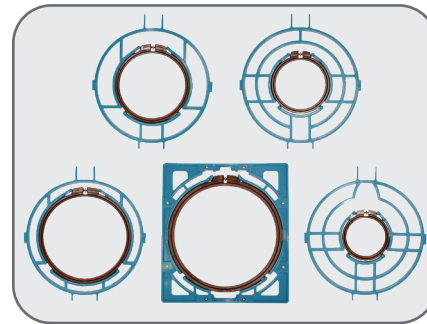

Spider Frames



Portal Frame



Signal Tower

LEM Server System [Option]

Quick and Easy Design Transfer to Machines using a Barcode Scanner.

- Able to connect up to 100 Barudan machines.
- Production Efficiency Reporting is available on the LEM Pro version and is even accessible from anywhere via the web.
- "Report" what head on which machines need maintenance.
- "See" what your machines are producing even from home.
- "Know" which employees and machines are more productive.

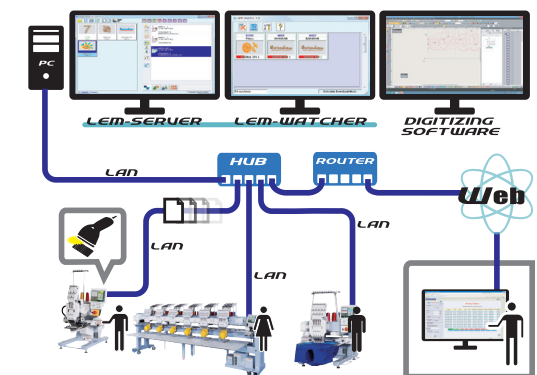

BARUDAN CO., LTD.



■ Sales Headquarter
20 Tsukagoshi, Josuiji, Ichinomiya-city, Aichi-pref.,
491-0004 Japan
Phone +81 586-76-1137
Fax +81-586-77-1499
URL <http://www.barudan.co.jp/>
E-mail info@barudan.co.jp

Agent:

BEKT-S1501CII

MODEL
BEKT-S1501CII



- Frame Centering Function
- Frame Limit Function
Able to restrict machine operation when a design does not fit to the frame or when there is a risk of a needle bar hitting the frame.
- Shortcuts
Customize most-used icons to save time.
- LAN Connector Standard, 2 USB ports
- Touch screen (8.4 inch, Resolution 800×600)
- 70 million stitch capacity, 100 memory locations

Name Drop

Separates names in a multiple name design for view and sewing purposes.



Name Drop Drive Mode



Name in Name List



Name in Thumbnail List

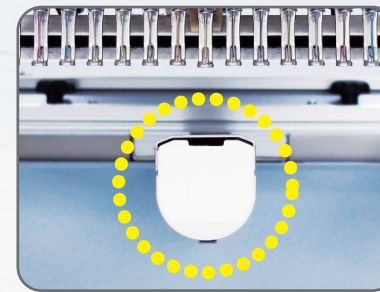

New trimmer system along with smaller diameter cylinder arm allows for sewing deeper into confined areas.

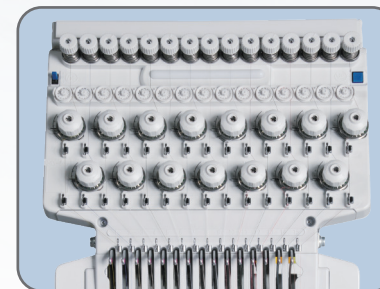

New tensioner system provides better and easier thread tensioning and improved thread break accuracy.

Features

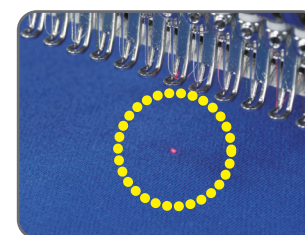

Laser Pointer



LED Back Light

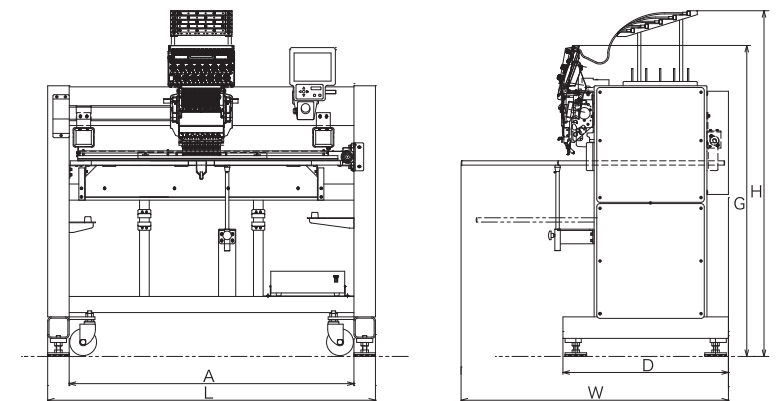

Machine Specifications / Main Dimensions

| MODEL | Embroidery Area (mm) | Cap Frame (mm) | Frames for Finished Products Maximum (mm) | Number of Needles | Stitch Length (mm) | Speed (rpm) | Power Supply (v) | Power Consumption (kw) | Dimensions (mm) | | | | | | Weight (kg) |
|---------------|----------------------|----------------|---|-------------------|--------------------|--|------------------|------------------------|-----------------|------|------|------|-----|------|-------------|
| | | | | | | | | | L | W | H | A | D | G | |
| BEKT-S1501CII | 450×520 | 79×360 | 460×434 | 15 | 0.1~12.7 | (Tubular Frame) 200~1300 (Cap Frame) 200~1000 | 1φ100~240 | 0.225 | 1525 | 1244 | 1608 | 1325 | 770 | 1447 | 350 |

- The embroidery area indicated above allows for maximum pantograph movement. The frame used may restrict the actual embroidery field size.
- Machines and Specifications are subject to change at any time without prior notice.